5. Schematic Diagrams

Block Identification of Main PCB	5-2
5-1 S.M.P.S. (Free Voltage ; SVR-433/233/230B/230W/131)	5-3
5-2 S.M.P.S. (230 Voltage ; SVR-2301)	5-4
5-3 Power Drive	5-5
5-4 System Control/Servo/Display/F-AV/Shuttle	5-6
5-5 Audio/Video/OSD	5-7
5-6 TM-Block/Input-Output	5-8
5-7 Remote-Control (Multi-TV)	5-9
5-8 Remote-Control (VCR Only)	5-10

Note

For schematic Diagram
 - Resistors are in ohms, 1/8W unless otherwise noted.

Special note :

Most semiconductor devices are electrostatically sensitive and therefore require the special handling techniques described under the "electrostatically sensitive (ES) devices" section of this service manual.

Note :

Do not use the part number shown on this drawing for ordering. The correct part number is shown in the parts list (may be slightly different or amended since this drawing was prepared).

Important safety notices :

Components identified with the mark ⚠ have the special characteristics for safety. When replacing any of these components. Use only the same type.

Block Identification of Main PCB

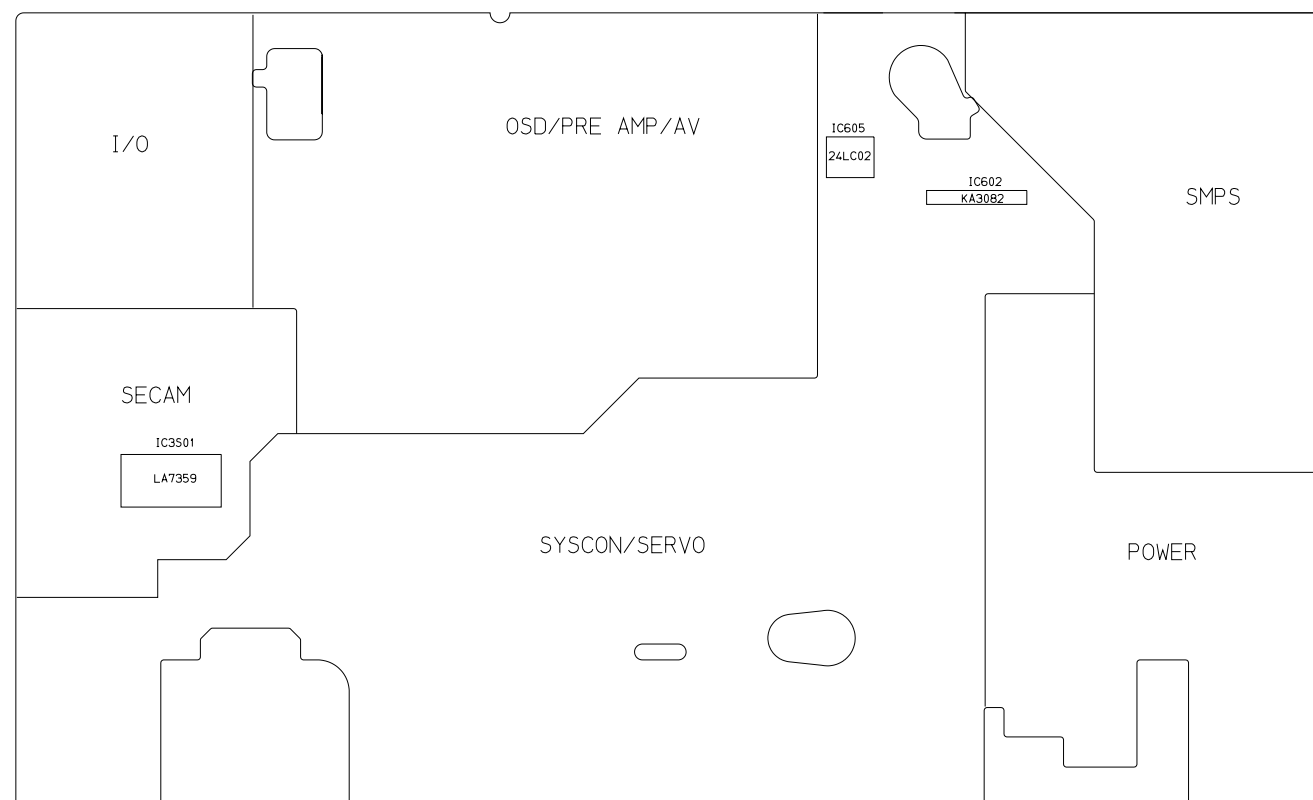

Component Side

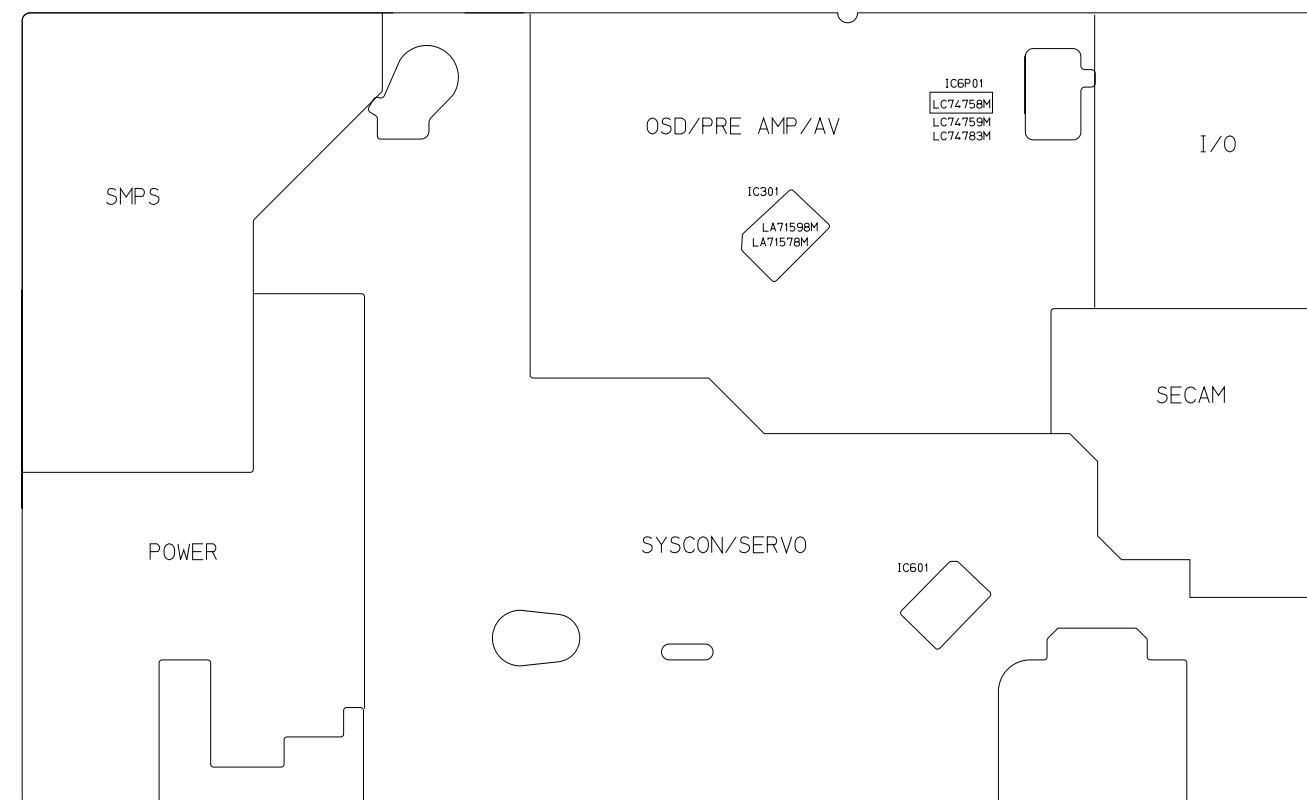

Conductor Side

5-1 S.M.P.S. (Free Voltage ; SVR-433/233/230B/230W/131)

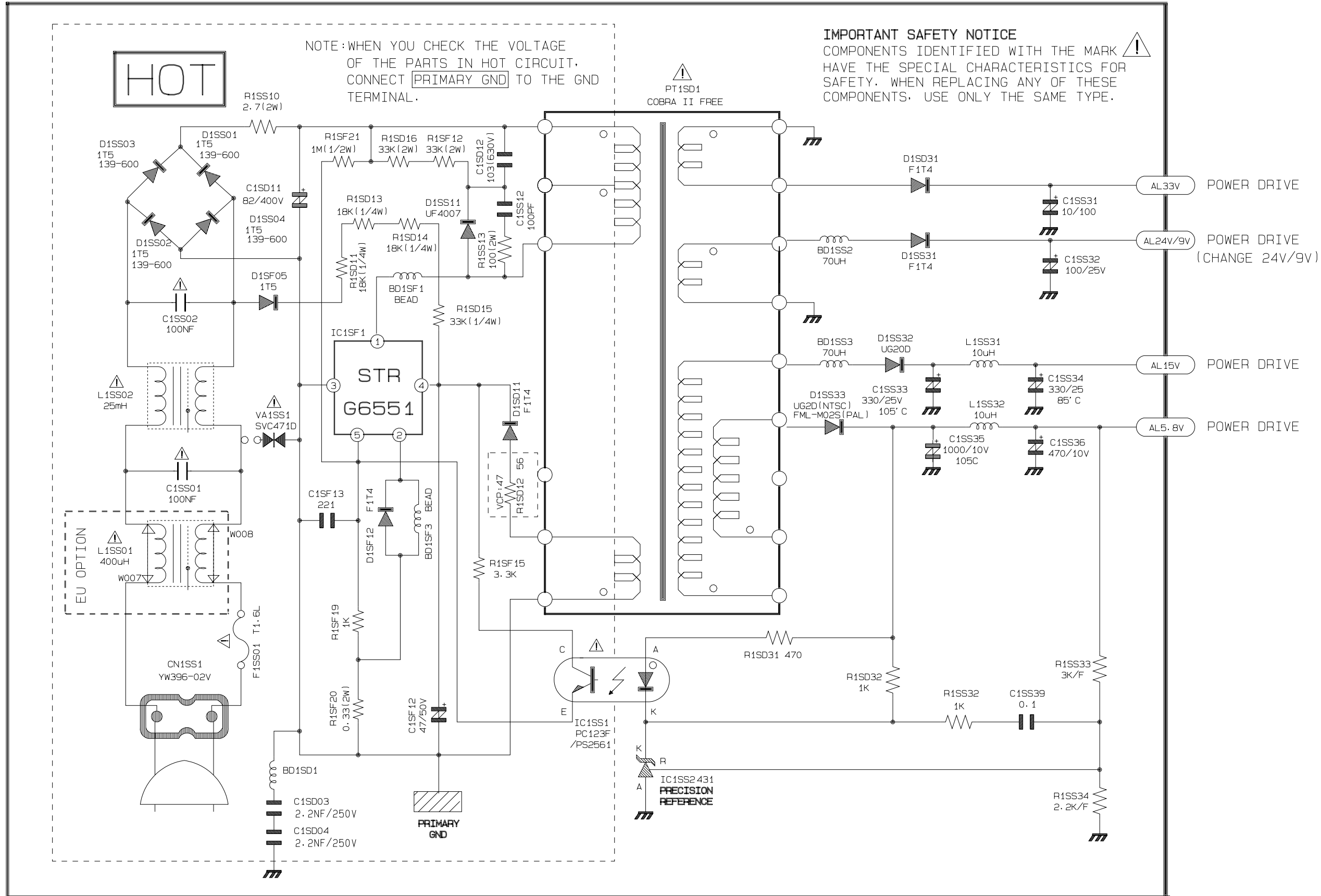

5-2 S.M.P.S. (230 Voltage ; SVR-2301)

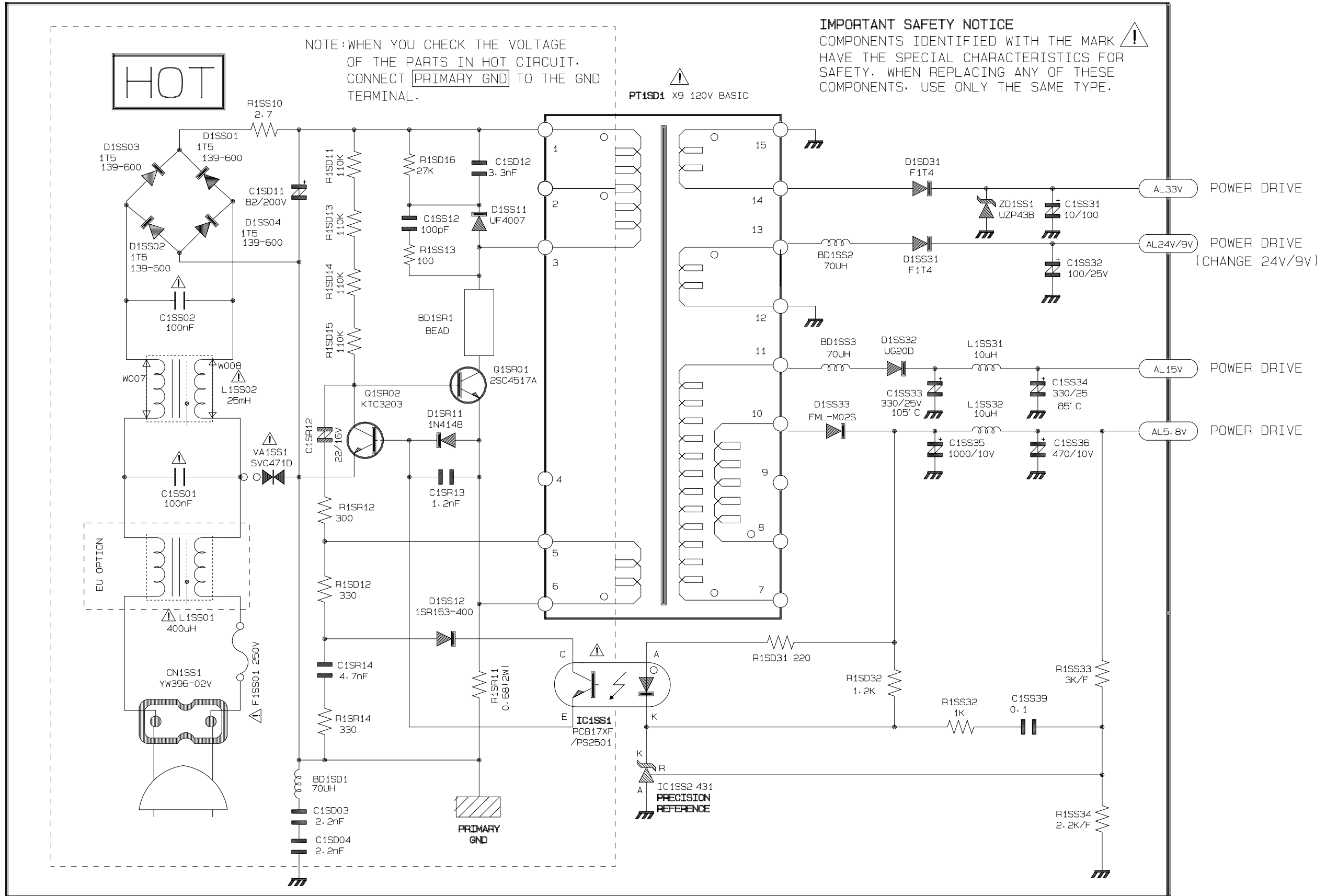

5-3 Power Drive

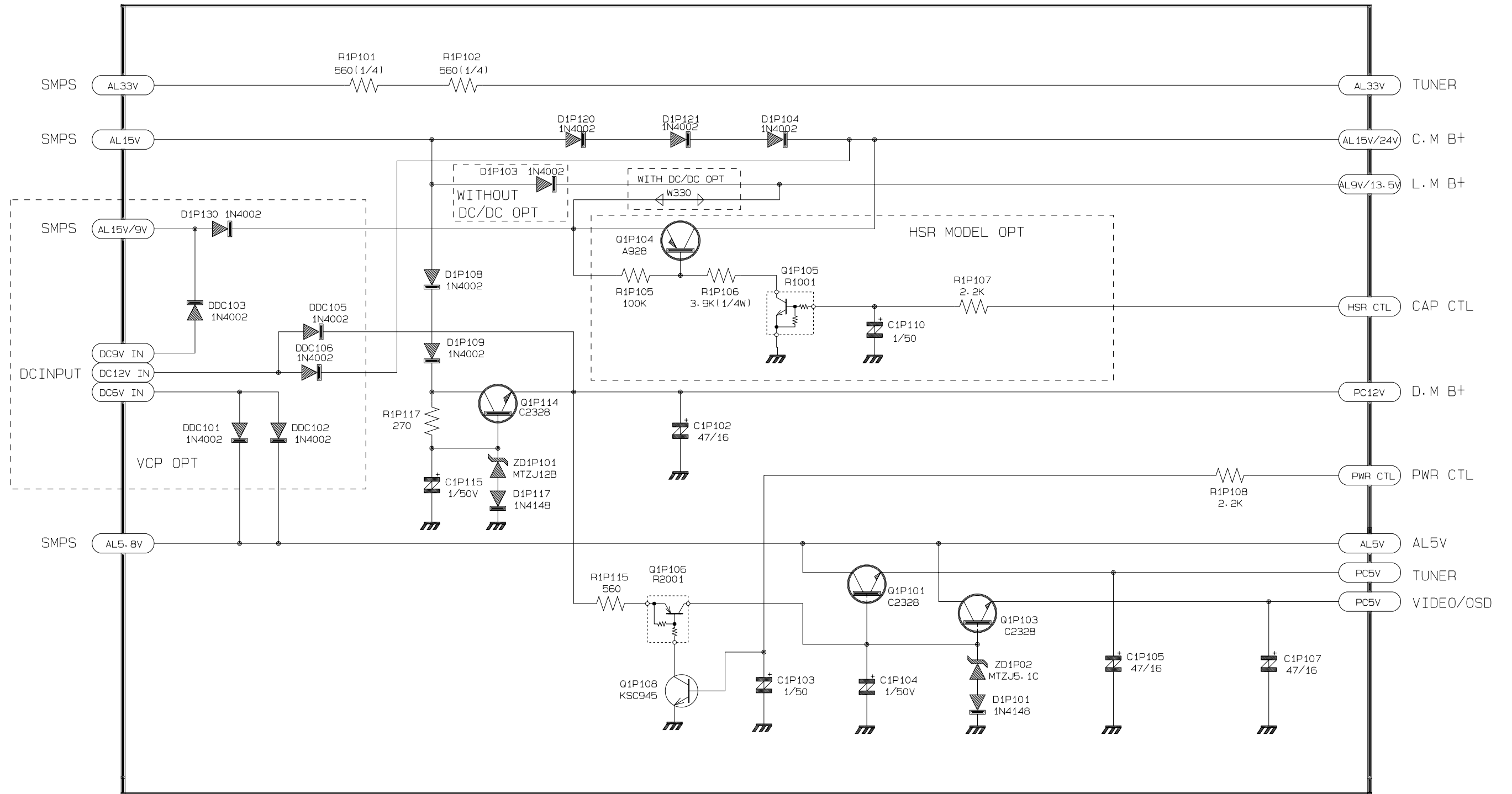

5-4 System Control/Servo/Display/F-AV/Shuttle

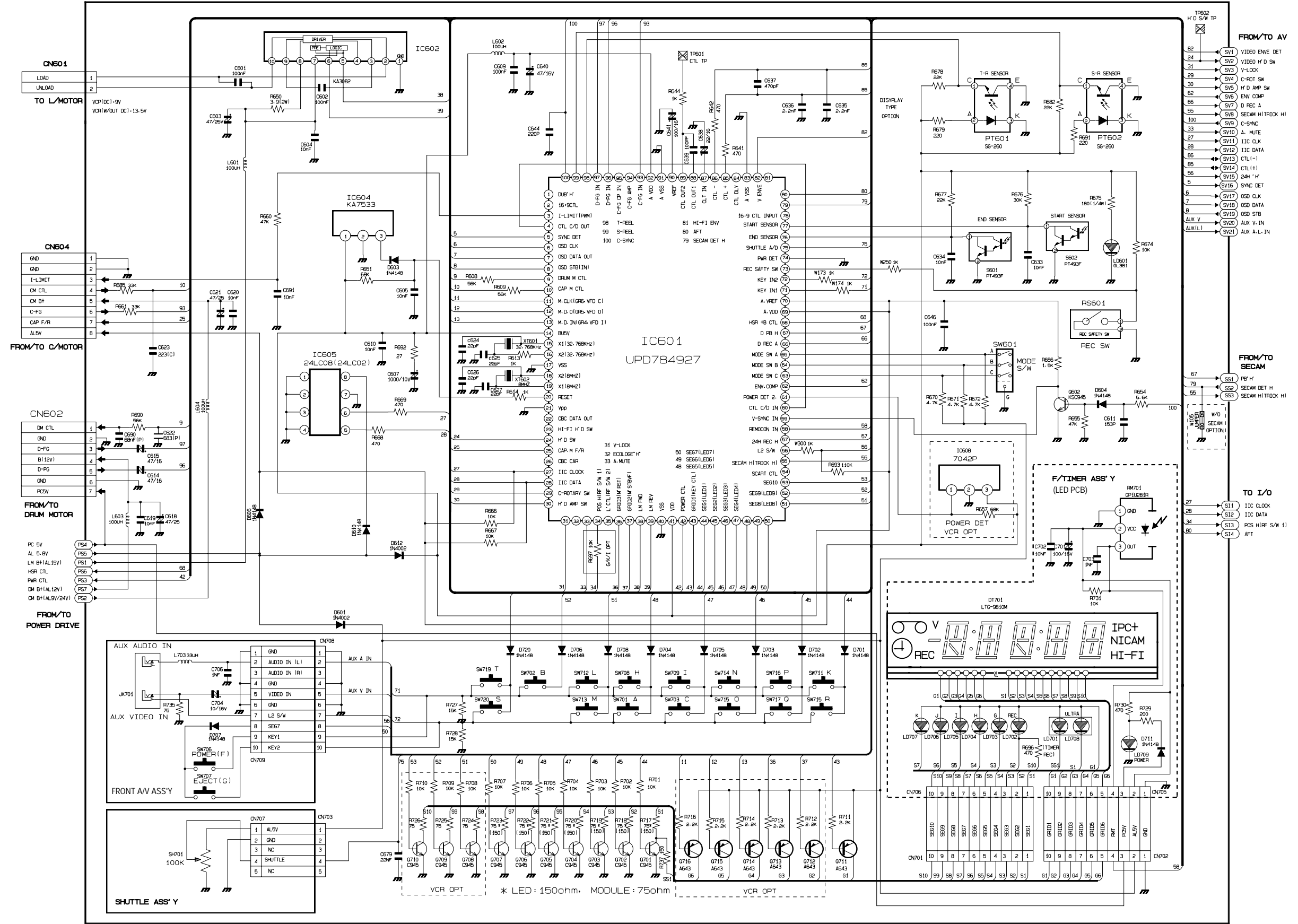

5-5 Audio/Video/OSD

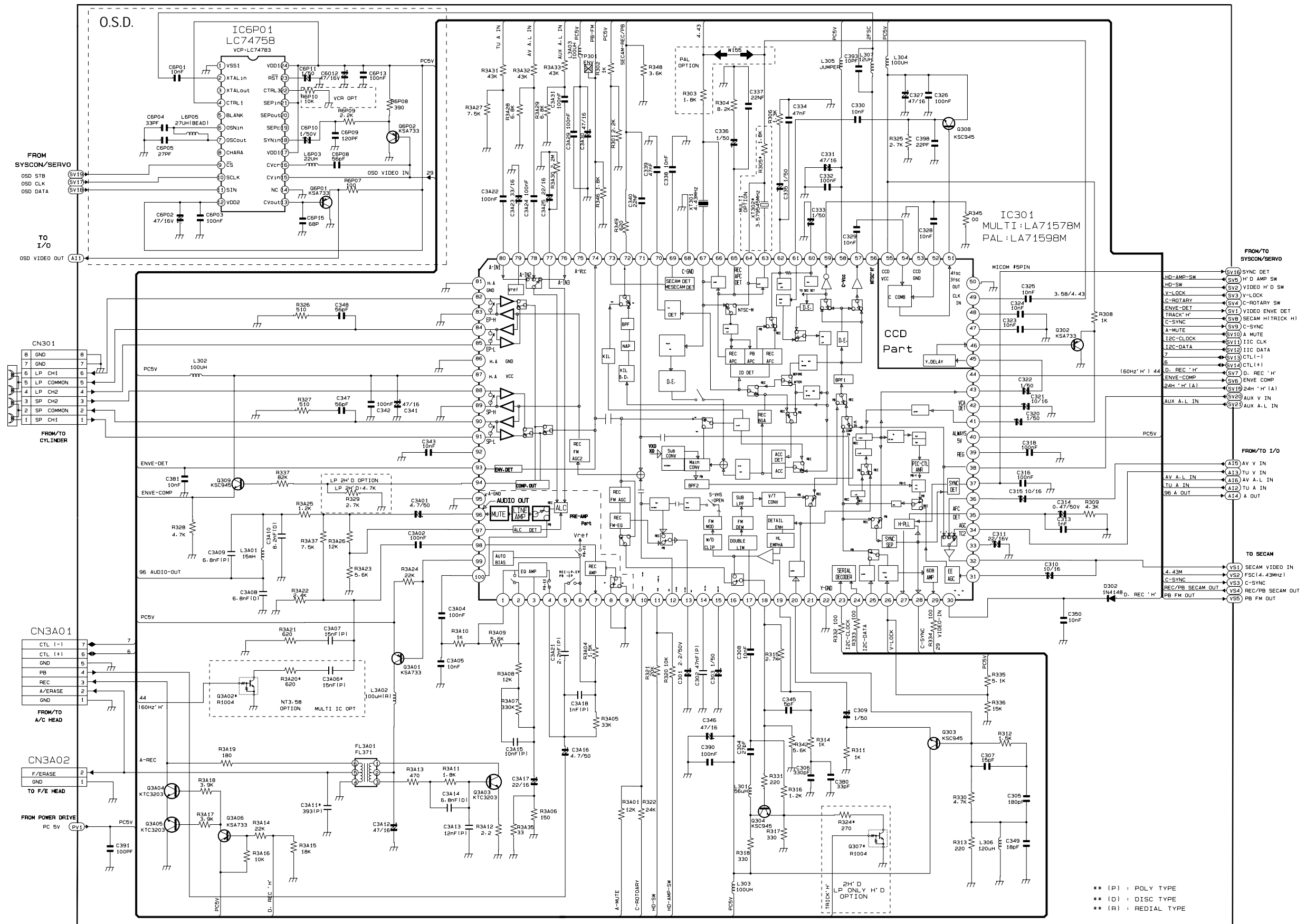

5-6 TM-Block/Input-Output

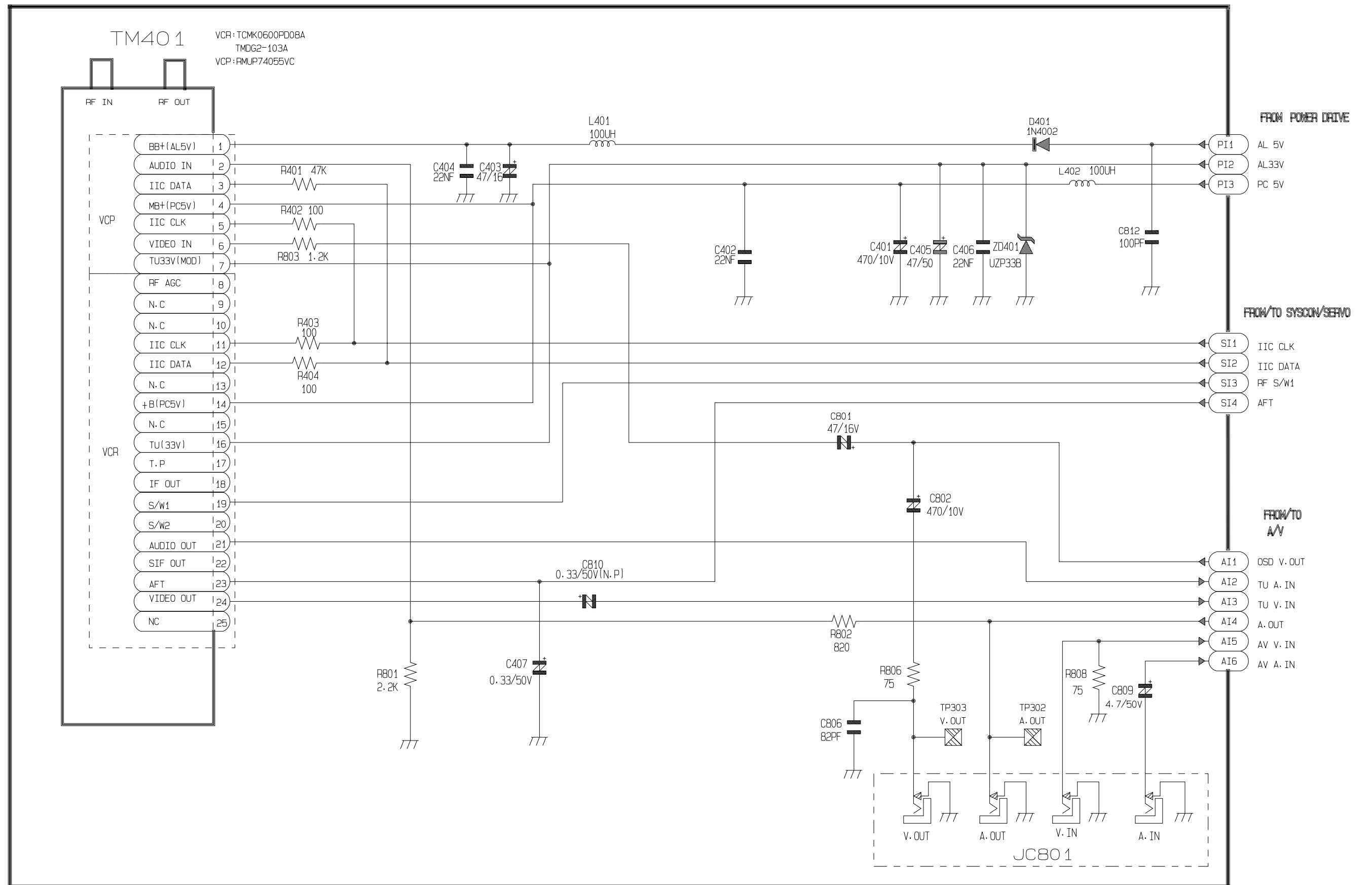

5-7 Remote-Control (Multi-TV)

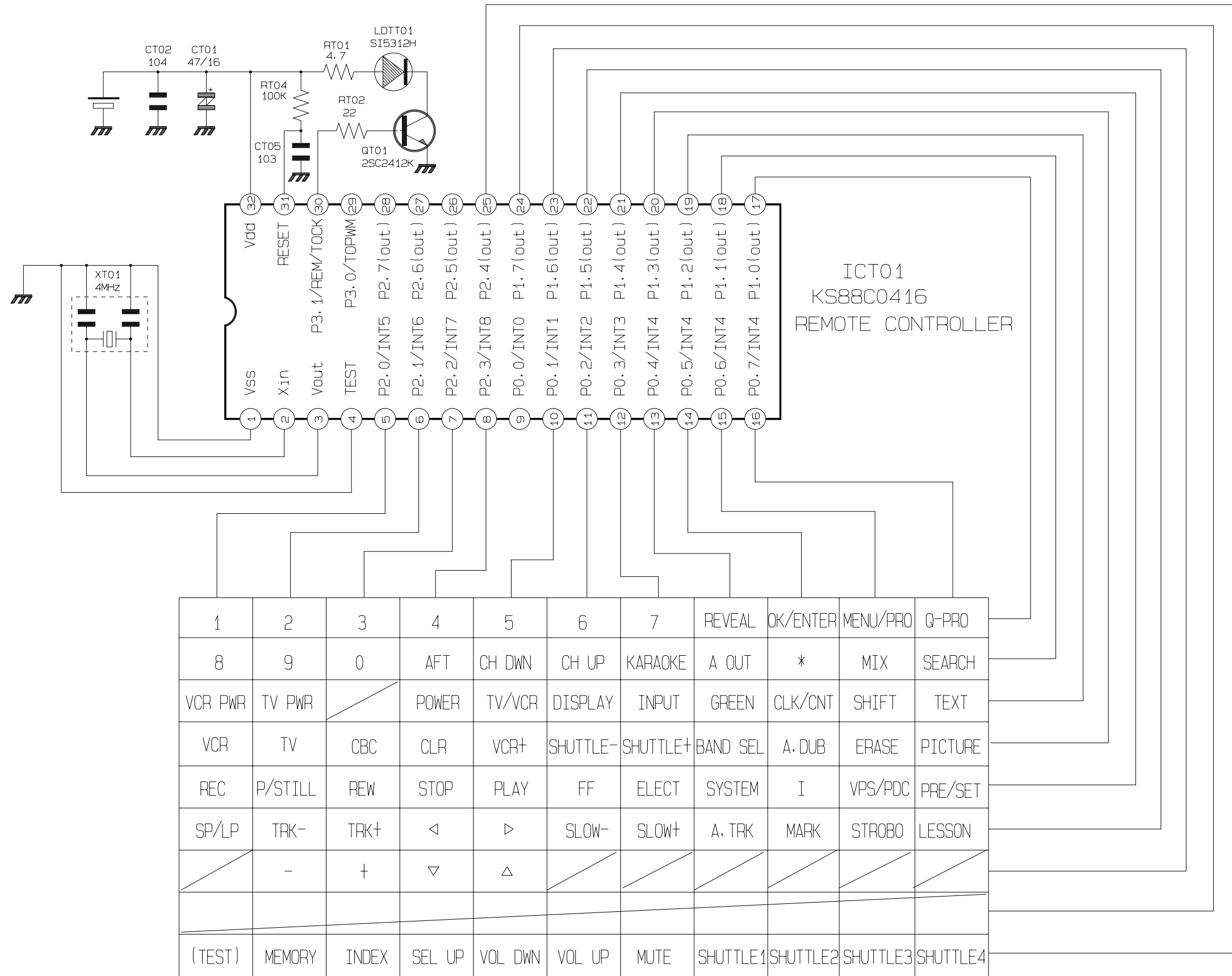

5-8 Remote-Control (VCR Only)

